

# Keysight Technologies

## Low PIM Coaxial Switches

DC to 26.5 GHz

Data Sheet





## Introduction

Keysight Technologies, Inc. low PIM coaxial switches provide ultra-low passive intermodulation (PIM) performance for applications where two or more transmitted signals share a common antenna or whenever the transmitter signal is too high or the receiver is sensitive to high intermodulation. These low PIM switches can help to keep the system PIM level low. A 0.03 dB insertion loss repeatability and 3 million cycles of operating life ensures signal integrity, improves testing efficiency, and ultimately maximizes test throughput.

### Key features

- Low PIM performance of  $-160$  dBc to keep your system PIM level low
- 0.03 dB IL repeatability, ensures accuracy and reduces calibration cycles
- 3 million cycles per section of operating life, reduces cost of test and ensures reliability of the test system life expectancy
- Excellent isolation minimizes cross-talk between channels to ensure signal integrity

## Specifications

Specifications refer to the performance standards or limits against which the switch is tested. Specifications are subject to change.

Specifications		
87104P/87104Q/87104R/87106P/87106Q/87106R		
Frequency range	DC to 26.5 GHz	
SWR	DC to 4 GHz:	< 1.20
	4 to 12.4 GHz:	< 1.35
	12.4 to 20 GHz:	< 1.45
	20 to 26.5 GHz:	< 1.70
Insertion loss (dB, maximum)	0.3 + 0.015 f, where f is specified in GHz	
Isolation (dB)	DC to 12 GHz:	> 100
	12 to 15 GHz:	> 80
	15 to 20 GHz:	> 70
	20 to 26.5 GHz:	> 65
PIM level (typical)	-160 dBc	
Operating life cycle (minimum)	3 million	
Insertion loss repeatability (maximum)	0.03 dB	
Connectors	SMA (f)	
87222R		
Frequency range	DC to 26.5 GHz	
SWR	DC to 4 GHz:	< 1.15
	4 to 12.4 GHz:	< 1.25
	12.4 to 20 GHz:	< 1.40
	20 to 26.5 GHz:	< 1.65
Insertion loss (dB, maximum)	0.3 + 0.025 f, where f is specified in GHz	
Isolation (dB, minimum)	120 - 2 f, where f is specified in GHz	
PIM level (typical)	-160 dBc	
Operating life cycle (minimum)	3 million	
Insertion loss repeatability (maximum)	0.03 dB	
Connectors	SMA (f)	
87406Q/87606Q		
Frequency range	DC to 20 GHz	
SWR	DC to 4 GHz :	< 1.21
	4 to 10 GHz :	< 1.35
	10 to 15 GHz :	< 1.50
	15 to 18 GHz :	< 1.70
	18 to 20 GHz :	< 1.90
Insertion loss (dB, maximum)	0.34 + 0.033 f, where f is specified in GHz	
Isolation (dB)	DC to 12 GHz:	> 100
	12 to 15 GHz:	> 80
	15 to 20 GHz:	> 70
PIM level (typical)	-160 dBc	
Operating life cycle (minimum)	3 million	
Insertion loss repeatability (maximum)	0.03 dB	
Connectors	SMA (f)	
N1810T/N1810U/N1811T/N1812U		
Frequency range	DC to 26.5 GHz	
SWR	DC to 4 GHz:	< 1.15
	4 to 12.4 GHz:	< 1.25
	12.4 to 20 GHz:	< 1.30
	20 to 26.5 GHz:	< 1.60
Insertion loss (dB, maximum)	0.35 + (0.45/26.5) f, where f is specified in GHz	
Isolation (dB)	90 - (30/26.5) f, where f is specified in GHz	
PIM level (typical)	-160 dBc	
Operating life cycle (minimum)	2 million <sup>1</sup>	
Insertion loss repeatability (maximum)	0.03 dB	
Connectors	SMA (f)	

Maximum power rating (for all models)	
Hot switching	- 1 W CW - 50 W peak, 10 μs max pulse width, not to exceed 1 W average

1. Option 124: Operating life, 1 million cycles minimum

## Passive Intermodulation

### 3rd Order intermodulation for two carriers at 43.0 dBm

1 carrier frequency	2nd carrier frequency	PIM frequency	PIM level
2110 MHz	2170 MHz	2050 MHz	-160 dBc (typical)

NOTE: PIM measurements may vary when different carrier frequencies, power levels and or PIM frequencies are used in the final application.

PIM testing is conducted as a part of the standard product acceptance test, with a test specification of -150 dBc.

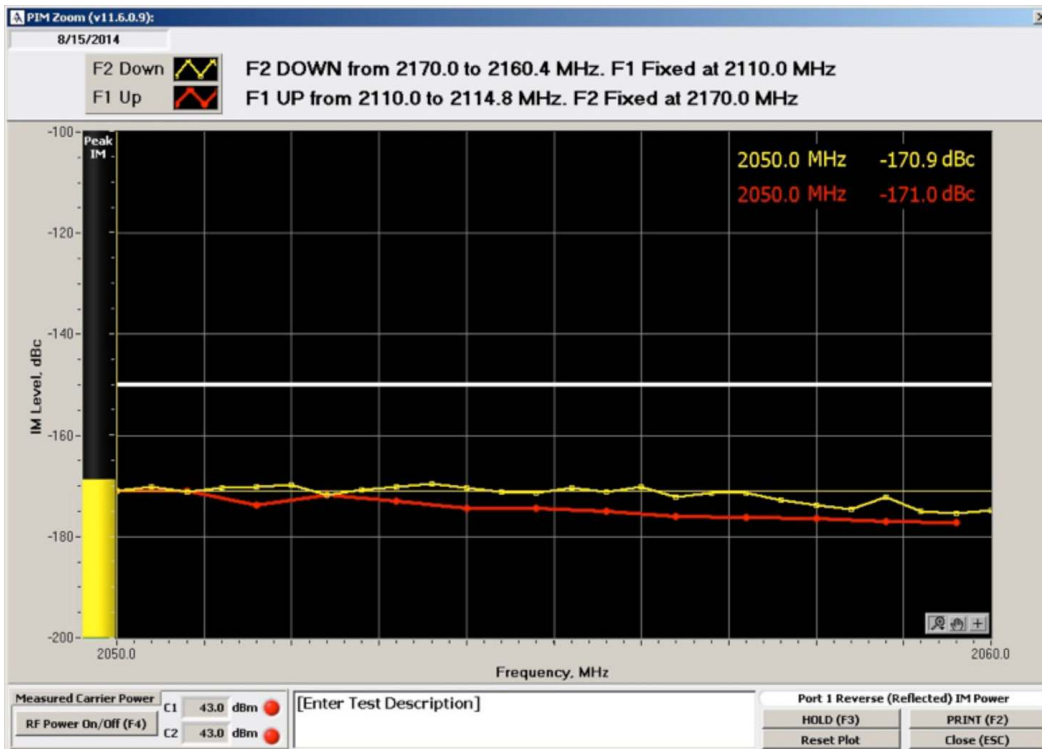

Screenshot of the PIM measurement.

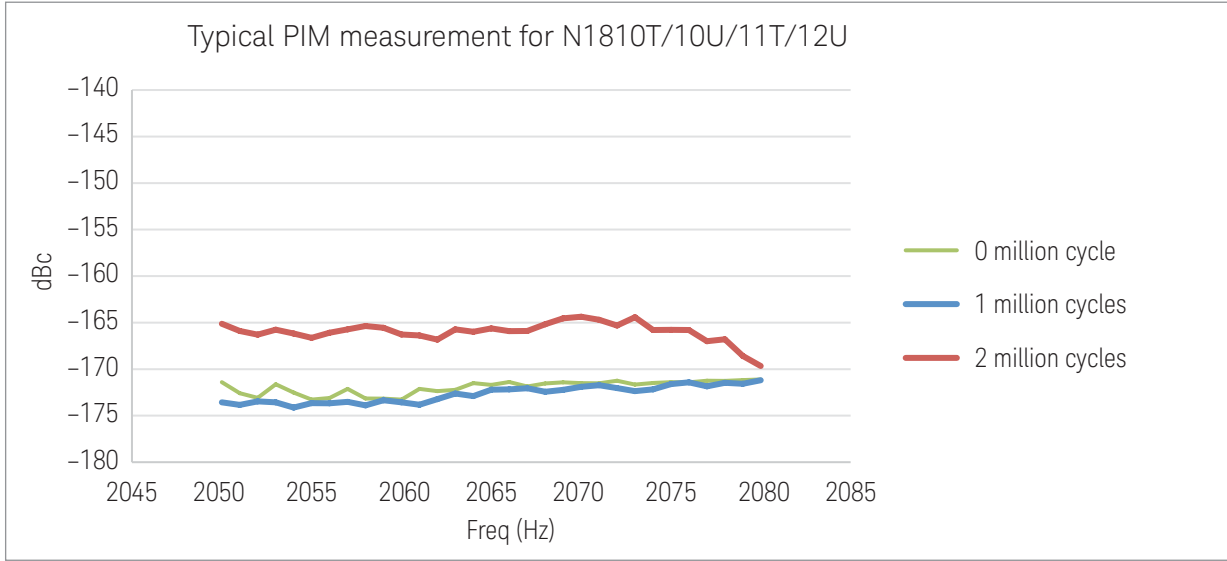

Typical PIM measurement at 0, 1 & 2 million cycle for N181x.

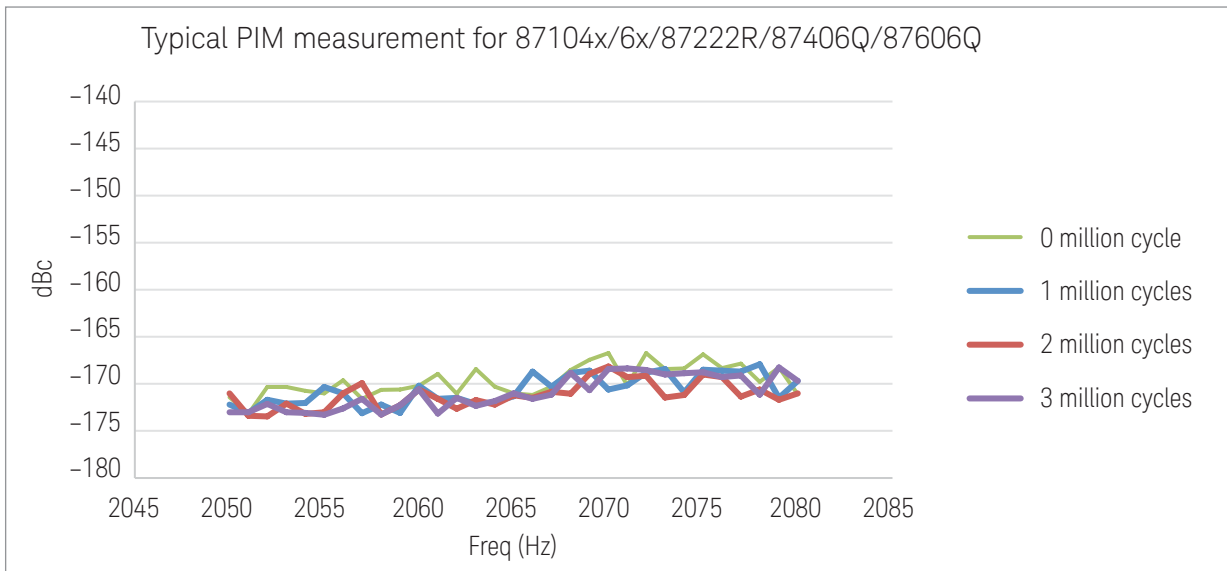

Typical PIM measurement at 0, 1, 2 & 3 million cycle for Multiport/Transfer/Matrix.

## Driving 87104P/Q/R and 87106P/Q/R

Each RF path can be closed (selected) by applying ground (TTL “High” for option T24) to the corresponding “drive” pin. In general, all other RF paths are simultaneously opened by the internal logic.

RF path			Standard drive						5 V TTL drive (Option T24)4					
	VDC Pin 1	GND Pin 15	Pin 3	Pin 5	Pin 7	Pin 9	Pin 11	Pin 13	Pin 3	Pin 5	Pin 7	Pin 9	Pin 11	Pin 13
Path 1*	20 – 32 V	GND1	GND <sup>2,3</sup>	Open	Open	Open	Open	Open	High <sup>2,3</sup>	Low	Low	Low	Low	Low
Path 2			Open	GND <sup>2,3</sup>	Open	Open	Open	Open	Low	High <sup>2,3</sup>	Low	Low	Low	Low
Path 3			Open	Open	GND <sup>2,3</sup>	Open	Open	Open	Low	Low	High <sup>2,3</sup>	Low	Low	Low
Path 4*			Open	Open	Open	GND <sup>2,3</sup>	Open	Open	Low	Low	Low	High <sup>2,3</sup>	Low	Low
Path 5			Open	Open	Open	Open	GND <sup>2,3</sup>	Open	Low	Low	Low	Low	High <sup>2,3</sup>	Low
Path 6			Open	Open	Open	Open	Open	GND <sup>2,3</sup>	Low	Low	Low	Low	Low	High <sup>2,3</sup>

\* Path 1 and 4 not connected for 87104P/Q/R.

### Switch drive specifications

Parameter	Conditions	Min	Nom	Max	Units
Supply voltage, Vcc		20	24	32	V
Supply current, Icc	Switching: Pulse width ≥ 15 ms; Vcc = 24 VDC <sup>5</sup>		200 <sup>5</sup>		mA
Quiescent current		25		50	mA
Switching speed				15	ms
5 V TTL drive specification (for Option T24 only)					
High level input		3		7	V
Low level input				0.8	V
Max high input current	Vcc = Max; V <sub>input</sub> = 3.85 VDC		1	1.4	mA

### Indicator specifications

Maximum withstand voltage: 60 V

Maximum current capacity: 150 mA

Maximum “ON” resistance: 2.5 Ω

Maximum “OFF” resistance: 10 GΩ

### Notes:

- Pin 15 must always be connected to ground to enable the electronic position indicating circuitry and drive logic circuitry.  
**CAUTION: IF PIN 15 IS NOT CONNECTED TO POWER SUPPLY GROUND, CATASTROPHIC FAILURE WILL OCCUR.**
- After the RF path is switched and latched, the drive current is interrupted by the electronic position sensing circuitry. Pulsed control is not necessary, but if implemented, the pulse width must be 15 ms minimum to ensure that the switch is fully latched.
- The default operation of the switch is break-before-make. Make-before-break switching can be accomplished by simultaneously selecting the old RF path “drive” pin and the new RF path “drive” pin. This will simultaneously close the old RF path and the new RF path. Once the new path is closed (15 ms), de-select the old RF path “drive” pin while leaving the new RF path “drive” pin selected. The switch circuitry will automatically open the old RF path while leaving the new RF path engaged.
- In addition to the quiescent current supplying the electronic position sensing circuitry, the drive current flows out of pin 15 (during switching) on TTL drive switches (Option T24).
- Closing one RF path requires 200 mA. Add 200 mA for each additional RF path closed or opened. Using all RF paths open (selecting pin 16) requires 200 mA per RF path reset with Vcc = 24 VDC.

## 87104P/Q/R, 87106P/Q/R Dimension and Drive Connection

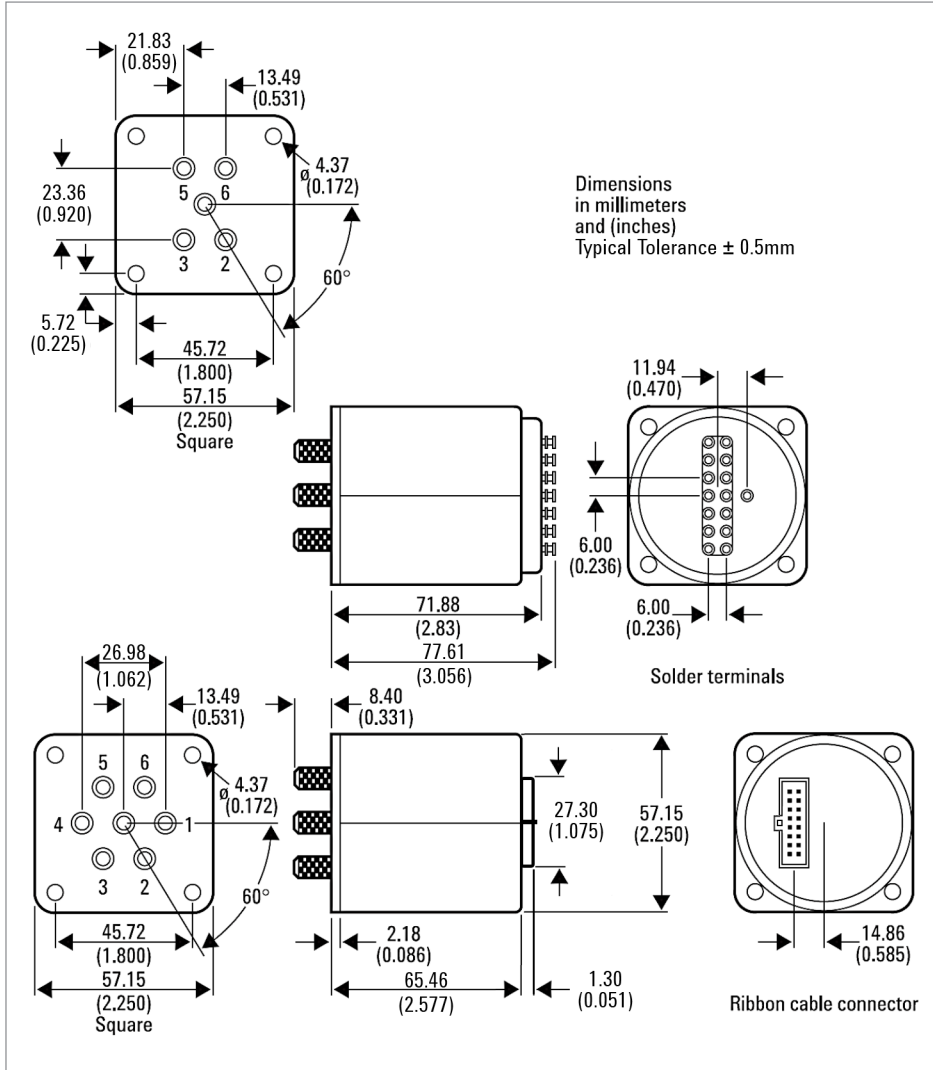

Figure 1. Product outlines

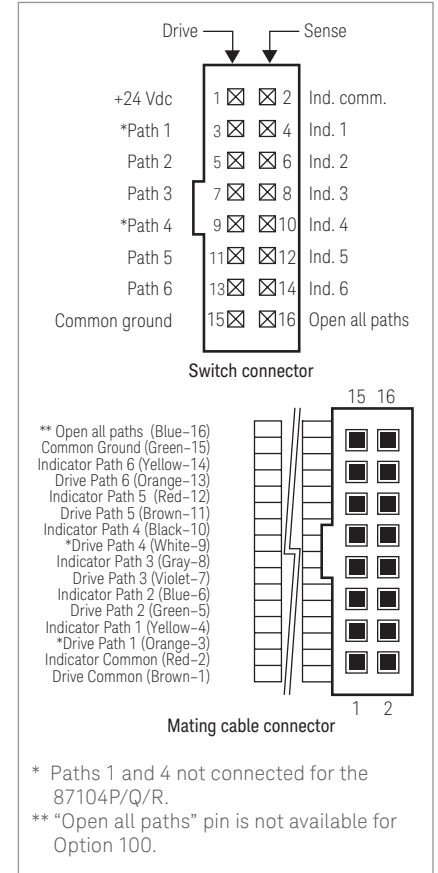

Figure 2. Drive connection diagrams with Option 161

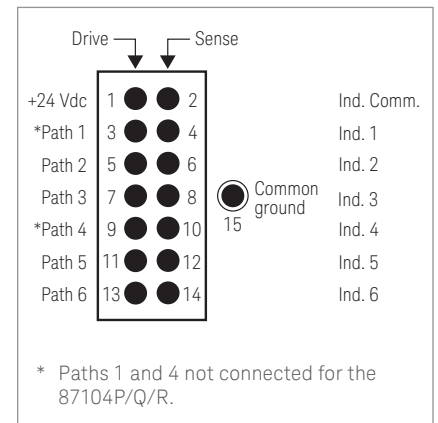

Figure 3. Drive connection diagrams with Option 100

## Driving 87222R

Each RF path can be closed (selected) by applying ground (or TTL “High”) to the corresponding “drive” pin.

RF path (refer to Figure 4)			Standard drive		Single line 5 V TTL drive <sup>2,4</sup>		Dual line 5 V TTL drive <sup>2,4</sup>	
	VDC Pin 1	GND Pin 9	Pin 3	Pin 5	Pin 7	Pin 8	Pin 7	Pin 8
Position A 1 to 2, 3 to 4	20 – 32 V	GND <sup>1,2</sup>	GND <sup>1,3</sup>	Open	High <sup>3</sup>	High <sup>3</sup>	High <sup>3</sup>	Low
Position B 2 to 3, 1 to 4			Open	GND <sup>1,3</sup>	Low	High <sup>3</sup>	Low	High <sup>3</sup>

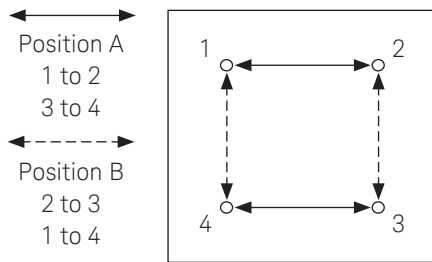

Figure 4. RF port connections

### Switch drive specifications

Parameter	Conditions	Min	Nom	Max	Units
Supply voltage, Vcc		20	24	32	V
Supply current, Icc	Switching: Pulse width $\geq$ 15 ms; Vcc = 24 VDC <sup>5</sup>		200		mA
Quiescent current		25		50	mA
Switching speed				15	ms
5 V TTL drive specification (for Option T24 only)					
High level input		3		7	V
Low level input				0.8	V
Max high input current	Vcc = Max; V <sub>input</sub> = 3.85 VDC		1	1.4	mA

### Indicator specifications

Maximum withstand voltage: 60 V  
 Maximum current capacity: 100 mA  
 Maximum “ON” resistance: 50  $\Omega$   
 Maximum “OFF” resistance: 1 G $\Omega$

**“CAUTION FOR USERS OF THE KEYSIGHT 11713B/C SWITCH DRIVER: Do not drive the 87222R using the S9 or S0 outputs from either the banana plugs or from pins 3 or 4 within the Atten X and Atten Y Viking sockets located on the rear panel of the 11713B/C.”**

### Notes:

- Pin 9 does not need to be grounded for the switch to operate in standard drive mode. If pin 9 is not grounded, the position indicators will only function while the appropriate drive has ground applied. Therefore, if a pulse drive is used and continuous indicator operation is required, pin 9 must be grounded.
- For TTL drive, pin 9 must be grounded.
- After the RF path is switched and latched, the drive current is interrupted by the electronic position sensing circuitry. Pulsed control is not necessary, but if implemented, the pulse width must be 15 ms minimum to ensure that the switch is fully latched.
- In addition to the quiescent current supplying the electronic position sensing circuitry, the drive current flows out of pin 9 (during switching) when using TTL drive.



## 87222R Dimension and Drive Connection

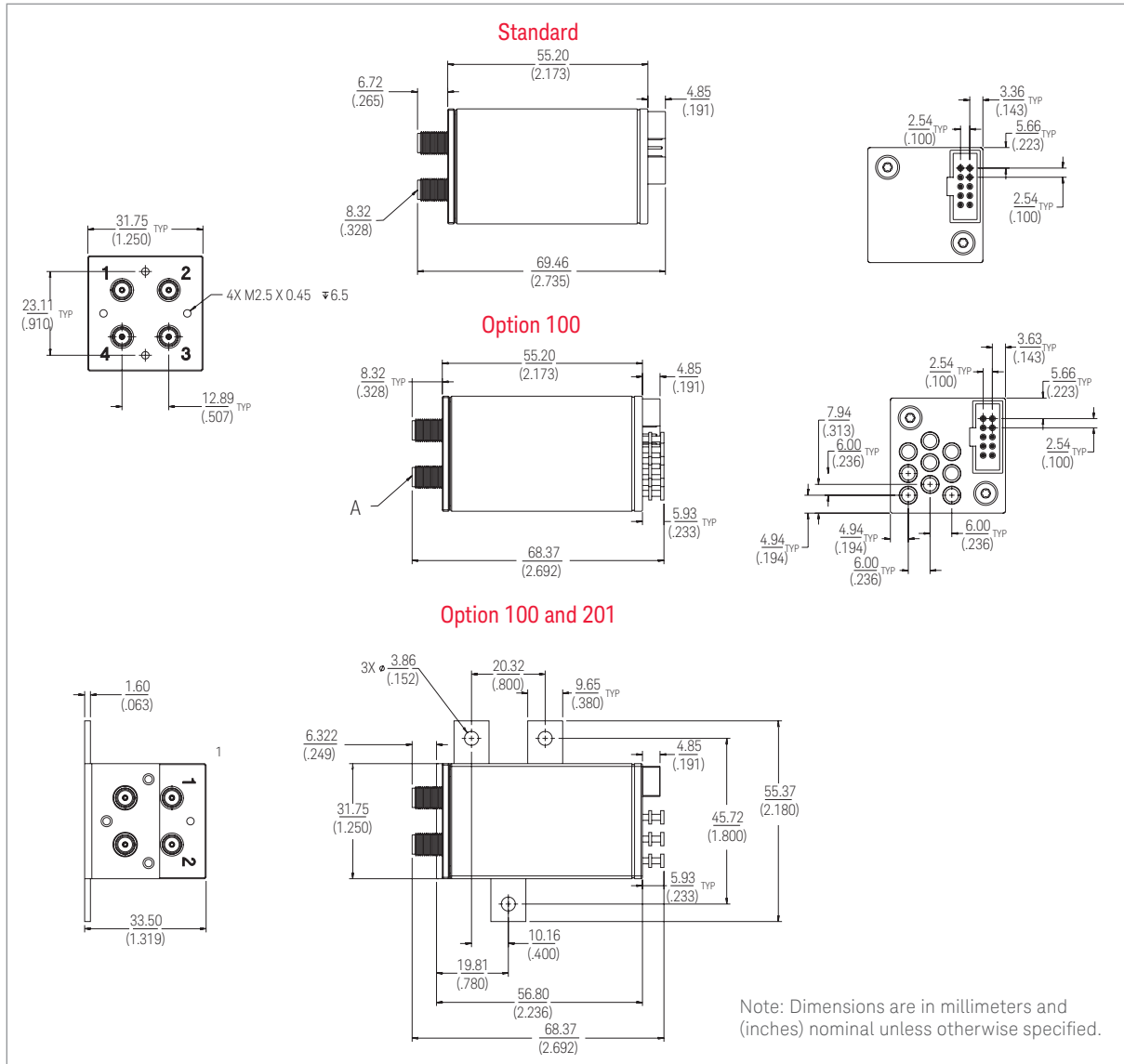

Figure 5.

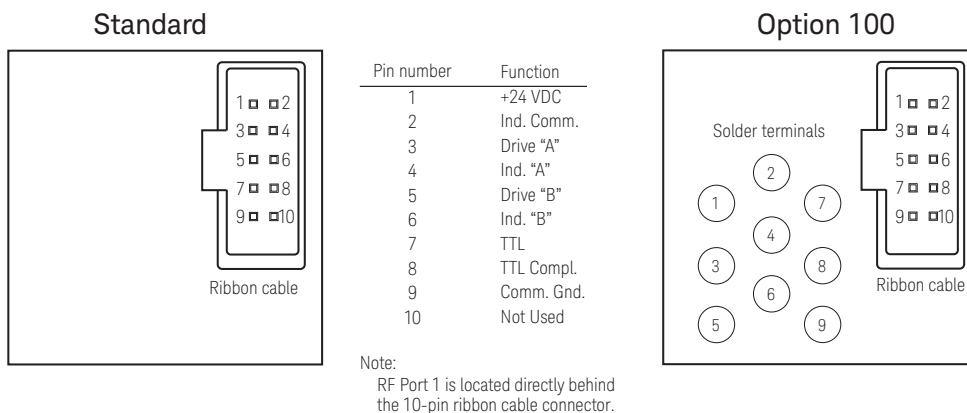

Figure 6. Drive connections

## Driving 87406Q

Each RF path can be closed (selected) by applying ground (TTL “High” for option T24) to the corresponding “drive” pin. To connect to any two ports, apply control signal to the corresponding “drive” pins as shown below. See *Dimension and Drive Connection* for drive connection diagrams.

RF port	6	5	4	3	2
1	Pin 3 & 13	Pin 3 & 11	Pin 3 & 9	Pin 3 & 7	Pin 3 & 5
2	Pin 5 & 13	Pin 5 & 11	Pin 5 & 9	Pin 5 & 7	
3	Pin 7 & 13	Pin 7 & 11	Pin 7 & 9		
4	Pin 9 & 13	Pin 9 & 11			
5	Pin 11 & 13				

Example: Configure the RF path from port 2 to port 5

RF port			1	2	3	4	5	6
Drive pin	VDC Pin 1	GND Pin 15	Pin 3	Pin 5	Pin 7	Pin 9	Pin 11	Pin 13
Standard drive			Open	GND <sup>2,3</sup>	Open	Open	GND <sup>2,3</sup>	Open
5 V TTL drive	20 – 32 V	GND <sup>1</sup>	Low	High <sup>2,3</sup>	Low	Low	High <sup>2,3</sup>	Low

Switch drive specifications

Parameter	Conditions	Min	Nom	Max	Units
Supply voltage, Vcc		20	24	32	V
Supply current, Icc	Switching: Pulse width $\geq$ 15 ms: Vcc = 24 VDC <sup>4</sup>		200 <sup>4</sup>		mA
Quiescent current		25		50	mA
Switching speed				15	ms
5 V TTL drive specification (for Option T24 only)					
High level input			3	7	V
Low level input				0.8	V
Max high input current	Vcc = Max; V <sub>input</sub> = 3.85 VDC		1	1.4	mA

Indicator specifications

Maximum withstand voltage: 60 V  
 Maximum current capacity: 150 mA  
 Maximum “ON” resistance: 2.5  $\Omega$   
 Maximum “OFF” resistance: 10 G $\Omega$

Notes:

- Pin 15 must always be connected to ground to enable the electronic position indicating circuitry and drive logic circuitry.  
**CAUTION: IF PIN 15 IS NOT CONNECTED TO POWER SUPPLY GROUND, CATASTROPHIC FAILURE WILL OCCUR.**
- After the RF path is switched and latched, the drive current is interrupted by the electronic position sensing circuitry. Pulsed control is not necessary, but if implemented, the pulse width must be 15 ms minimum to ensure that the switch is fully latched.
- The default operation of the switch is break-before-make. Make-before-break switching can be accomplished by simultaneously selecting the old RF path “drive” pin and the new RF path “drive” pin. This will simultaneously close the old RF path and the new RF path. Once the new path is closed (15 ms), de-select the old RF path “drive” pin while leaving the new RF path “drive” pin selected. The switch circuitry will automatically open the old RF path while leaving the new RF path engaged.
- Closing one RF path requires 200 mA, add 200 mA for each additional RF path closed or opened. Using all RF paths open (selecting pin 16) requires 200 mA per RF path reset with Vcc = 24 VDC.

## 87406Q Dimension and Drive Connection

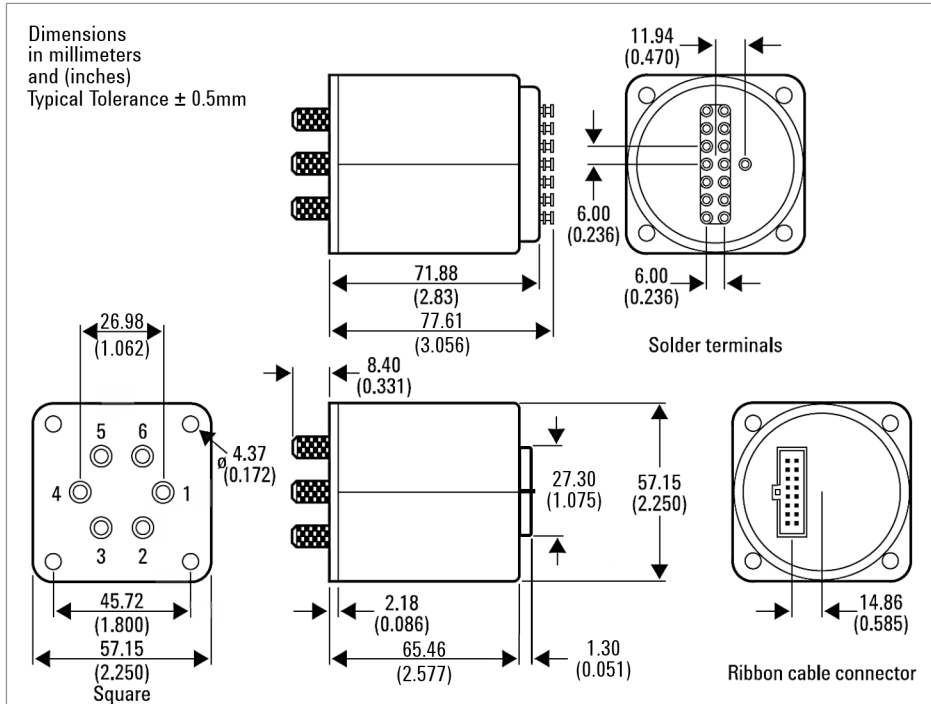

Figure 7. Product outline

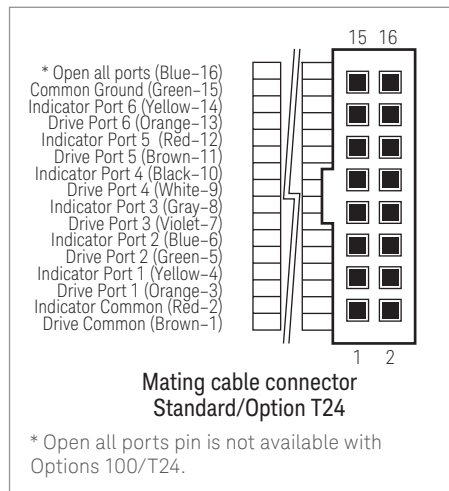
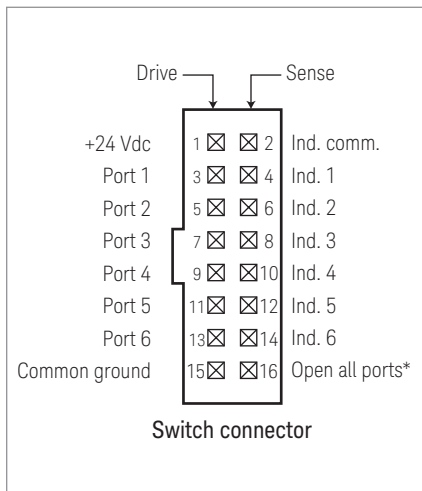

Figure 8. Drive connection diagrams

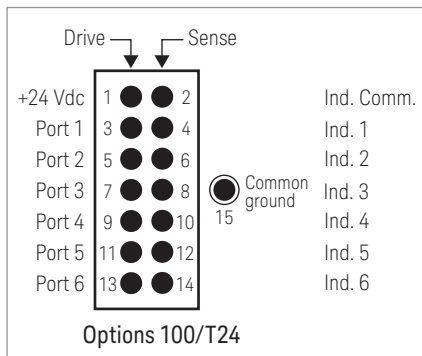

Figure 9. Drive connection diagrams

## Driving 87606Q

Each RF path can be closed (selected) by applying ground to the corresponding “drive” pin. To connect to any two ports, apply ground to the corresponding “drive” pins as shown below. See *Dimension and Drive Connection* for drive connection diagrams.

RF port	6	5	4	3	2
1	Pin 3 & 13	Pin 3 & 11	Pin 3 & 9	Pin 3 & 7	Pin 3 & 5
2	Pin 5 & 13	Pin 5 & 11	Pin 5 & 9	Pin 5 & 7	
3	Pin 7 & 13	Pin 7 & 11	Pin 7 & 9		
4	Pin 9 & 13	Pin 9 & 11			
5	Pin 11 & 13				

To open RF ports, apply ground to the corresponding drive pins as shown below. See *Dimension and Drive Connection* for drive connection diagrams.

RF port	1	2	3	4	5	6
Drive pin	Pin 4	Pin 6	Pin 8	Pin 10	Pin 12	Pin 14

Example: Configure the RF path from port 2 to port 5

RF port			1		2		3		4		5		6	
Drive pin	VDC Pin 1	GND Pin 15	Pin 3	Pin 4	Pin 5	Pin 6	Pin 7	Pin 8	Pin 9	Pin 10	Pin 11	Pin 12	Pin 13	Pin 14
Standard drive	20 – 32 V	GND <sup>1</sup>	Open	GND <sup>2</sup>	GND <sup>2</sup>	Open	Open	Open	Open	GND <sup>2</sup>	GND <sup>2</sup>	Open	Open	GND <sup>2</sup>

Switch drive specifications

Parameter	Conditions	Min	Nom	Max	Units
Supply voltage, Vcc		20	24	32	V
Supply current, Icc	Switching: Pulse width $\geq$ 15 ms: Vcc = 24 VDC <sup>3</sup>		200 <sup>3</sup>		mA
Quiescent current		25		50	mA
Switching speed				15	ms

Notes:

- Pin 15 must always be connected to ground to enable the electronic position indicating circuitry and drive logic circuitry.  
**CAUTION: IF PIN 15 IS NOT CONNECTED TO POWER SUPPLY GROUND, CATASTROPHIC FAILURE WILL OCCUR.**
- After the RF path is switched and latched, the drive current is interrupted by the electronic position sensing circuitry. Pulsed control is not necessary, but if implemented, the pulse width must be 15 ms minimum to ensure that the switch is fully latched.
- Closing one RF path requires 200 mA, add 200 mA for each additional RF path closed or opened. Using all RF paths open (selecting pin 16) requires 200 mA per RF path reset with Vcc = 24 VDC.

## 87606Q Dimension and Drive Connection

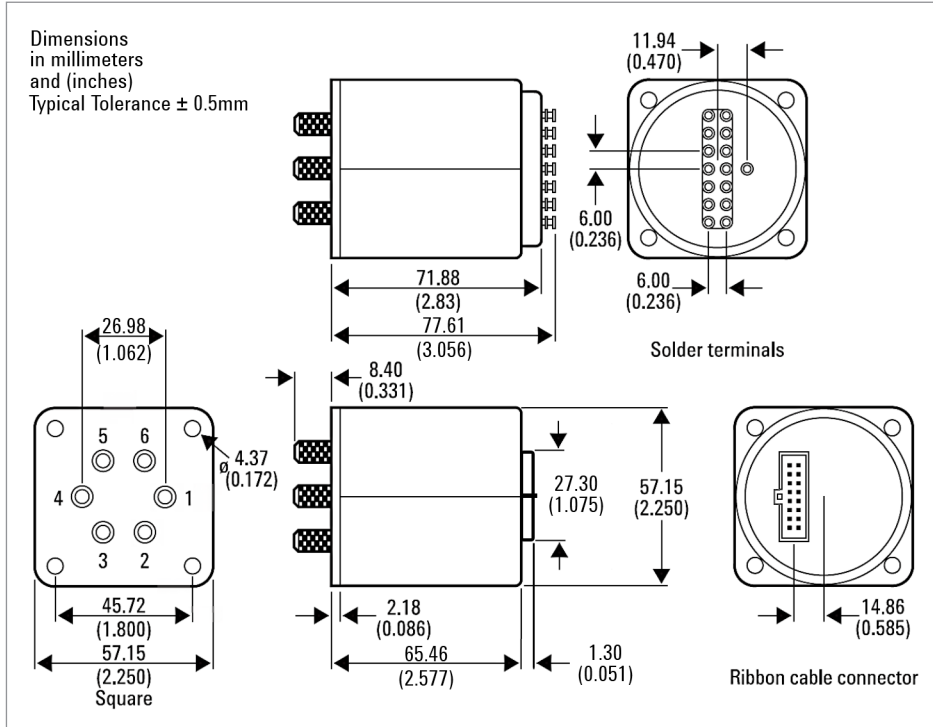

Figure 10. Product outline

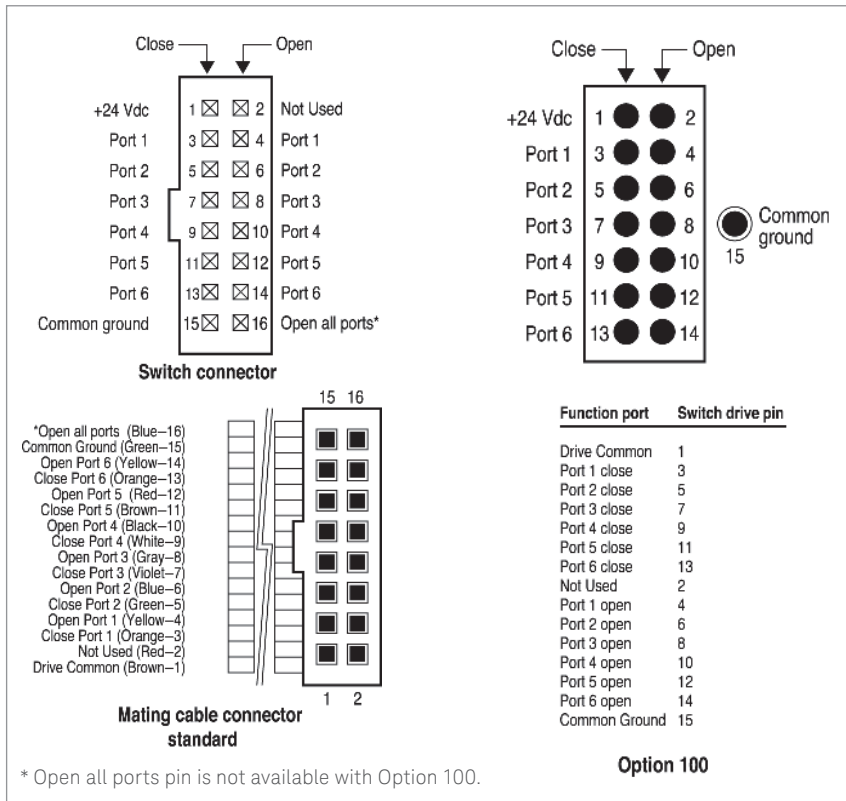

Figure 11. Drive connection diagrams

## Driving N1810U/10T/11T/12U

There are two positions for the N181x family of switches. Standard switching is accomplished by applying the supply voltage to pin 5 (+V) and grounding either pin 4 (A) or pin 3 (B) to actuate the mechanism to the desired state. See *Dimension and Drive Connection* for pin out diagrams.

RF path (refer to Figure 12)	Standard drive		Single line 5 V TTL drive			
	V+ Pin 5	GND Pin 1	Pin 3	Pin 5	Pin 7	Pin 8
Position A	V <sub>supply</sub>	GND <sup>1,2</sup>	GND <sup>1,2</sup>	Open	High <sup>1,2</sup>	Low
Position B			Open	GND <sup>1,2</sup>	Low	High <sup>1,2</sup>

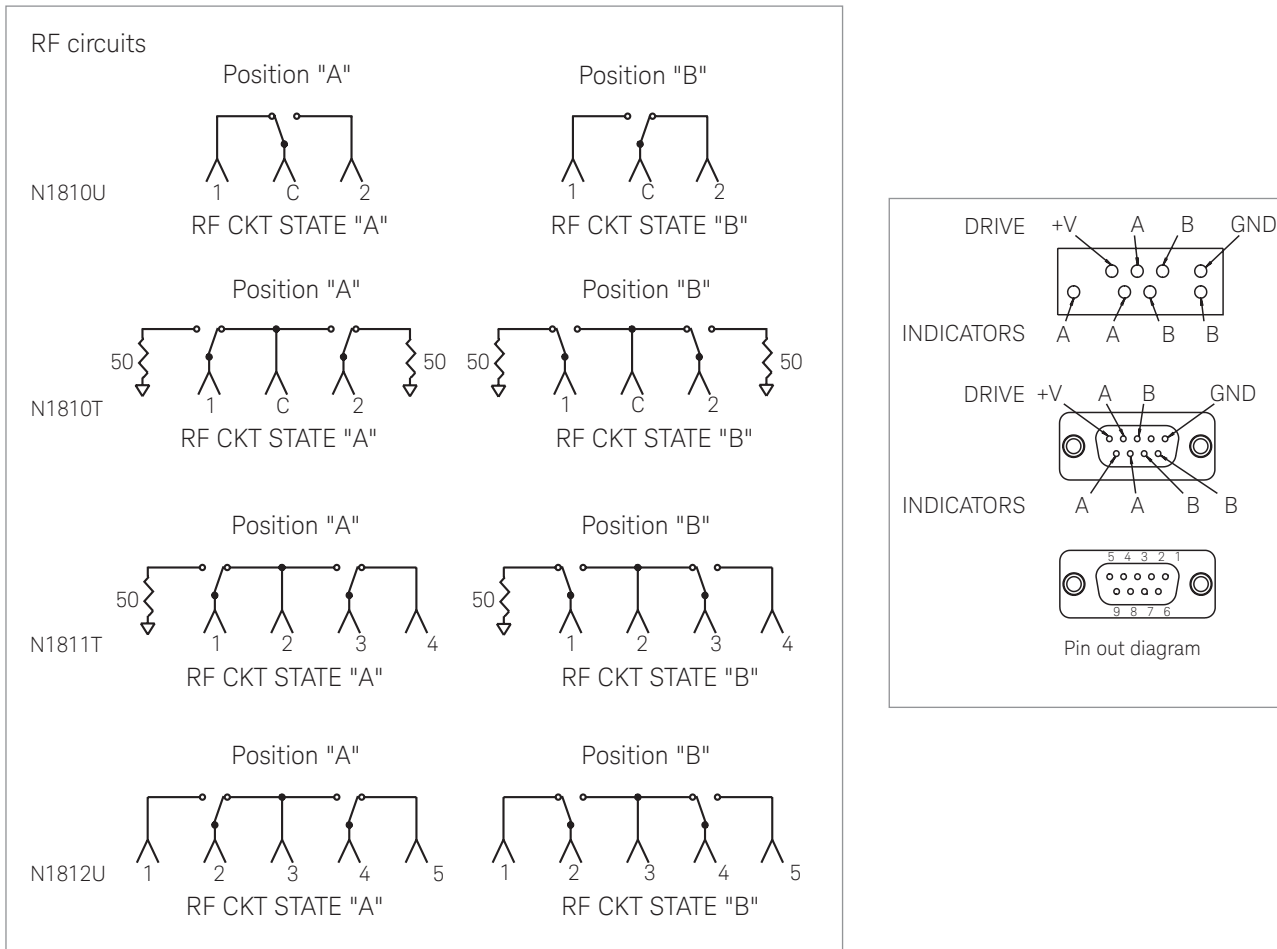

Figure 12.

Notes:

- Pin 1 (GND) must always be connected to ground.  
**CAUTION: IF PIN 1 IS NOT CONNECTED TO THE POWER SUPPLY GROUND, CATASTROPHIC FAILURE WILL OCCUR.**
- After the RF path is switched and latched, the drive current is interrupted by the electronic position sensing circuitry. Pulsed control is not necessary, but if implemented, the pulse width must be 15 ms minimum to ensure that the switch is fully latched.
- The default operation of the switch is break-before-make. Make-before-break switching can be accomplished by simultaneously selecting the old RF path "drive" pin and the new RF path "drive" pin. This will simultaneously close the old RF path and the new RF path. Once the new path is closed (15 ms), de-select the old RF path "drive" pin while leaving the new RF path "drive" pin selected. The switch circuitry will automatically open the old RF path while leaving the new RF path engaged.

## Switch Drive Specifications

<b>N1810U</b>							
Option	Parameter	Conditions	Min	Nom	Max	Units	
All options	Switching speed				15	ms	
105	Supply voltage, Vcc		4.5	5.0	7.0	V	
	Supply current, Icc	Supply voltage = 5 V		300		mA	
115 <sup>4</sup>	Supply voltage, Vcc		12.5	15.0	20.0	V	
	Supply current, Icc	Supply voltage = 15 V		125		mA	
124 <sup>5</sup>	Supply voltage, Vcc		20.0	24.0	32.0	V	
	Supply current, Icc	Supply voltage = 24 V		75		mA	
<b>5 V TTL drive specification</b>							
401	High level input		3.0		12.0	V	
	Low level input				1.0	V	
	Max high input current	Input voltage = 12.0 V				1.0	mA
		Input voltage = 3.85 V			0.25	0.5	mA

<b>N1810T/N1811T/N1812U</b>							
Option	Parameter	Conditions	Min	Nom	Max	Units	
All options	Switching speed				15	ms	
105	Supply voltage, Vcc		4.5	5.0	7.0	V	
	Supply current, Icc	Supply voltage = 5 V		600		mA	
115 <sup>4</sup>	Supply voltage, Vcc		12.5	15.0	20.0	V	
	Supply current, Icc	Supply voltage = 15 V		250		mA	
124 <sup>5</sup>	Supply voltage, Vcc		20.0	24.0	32.0	V	
	Supply current, Icc	Supply voltage = 24 V		150		mA	
<b>5 V TTL drive specification</b>							
401	High level input		3.0		12.0	V	
	Low level input				1.0	V	
	Max high input current	Input voltage = 12.0 V				1.0	mA
		Input voltage = 3.85 V			0.25	0.5	mA

**Notes:**

4. Option 115: Operating life, 2 million cycles minimum except 1 million cycles minimum when driven at voltages 18-20 VDC.
5. Option 124: Operating life, 1 million cycles minimum.

# N1810U/10T/11T/12U Dimension and Drive Connection

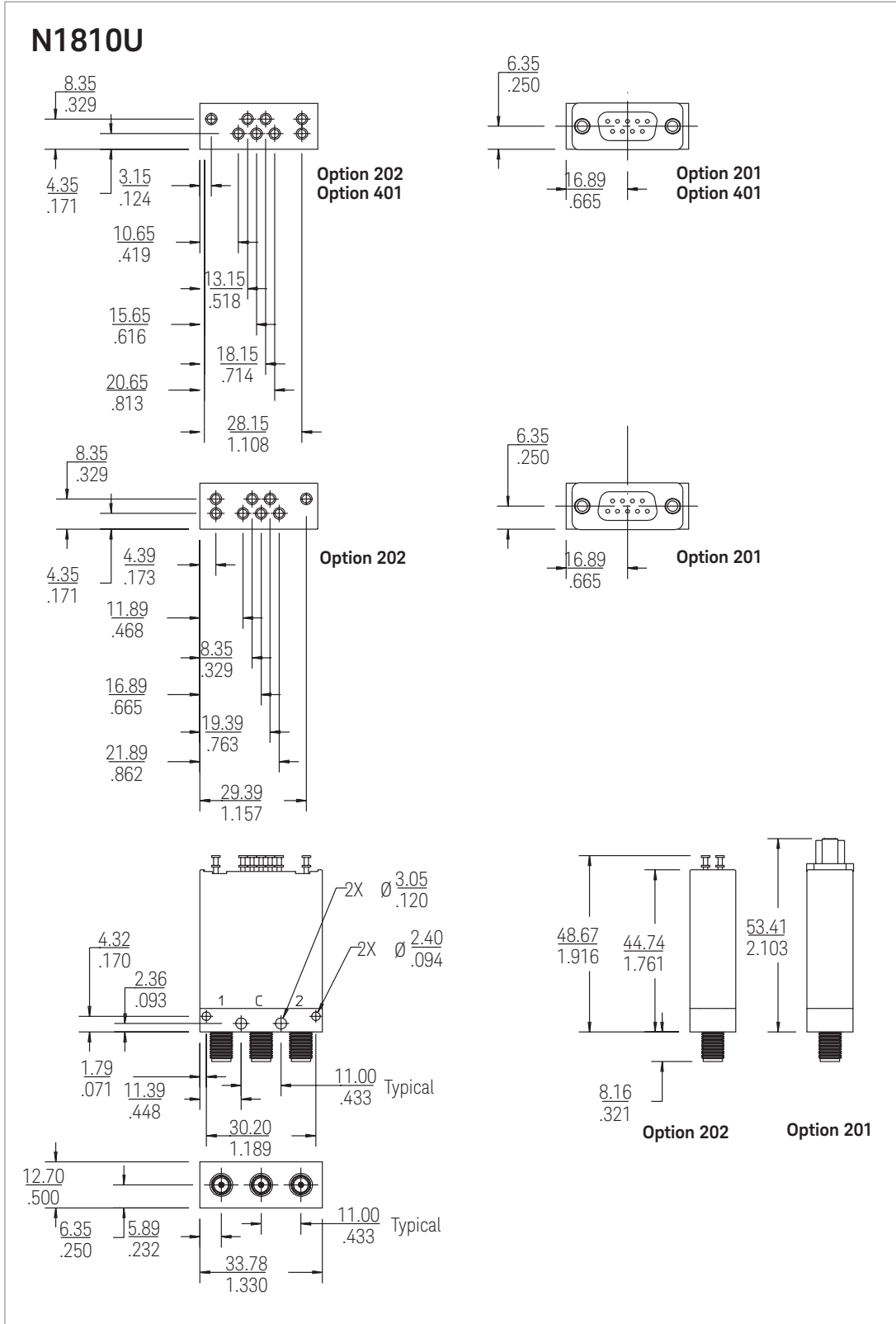

Figure 13.



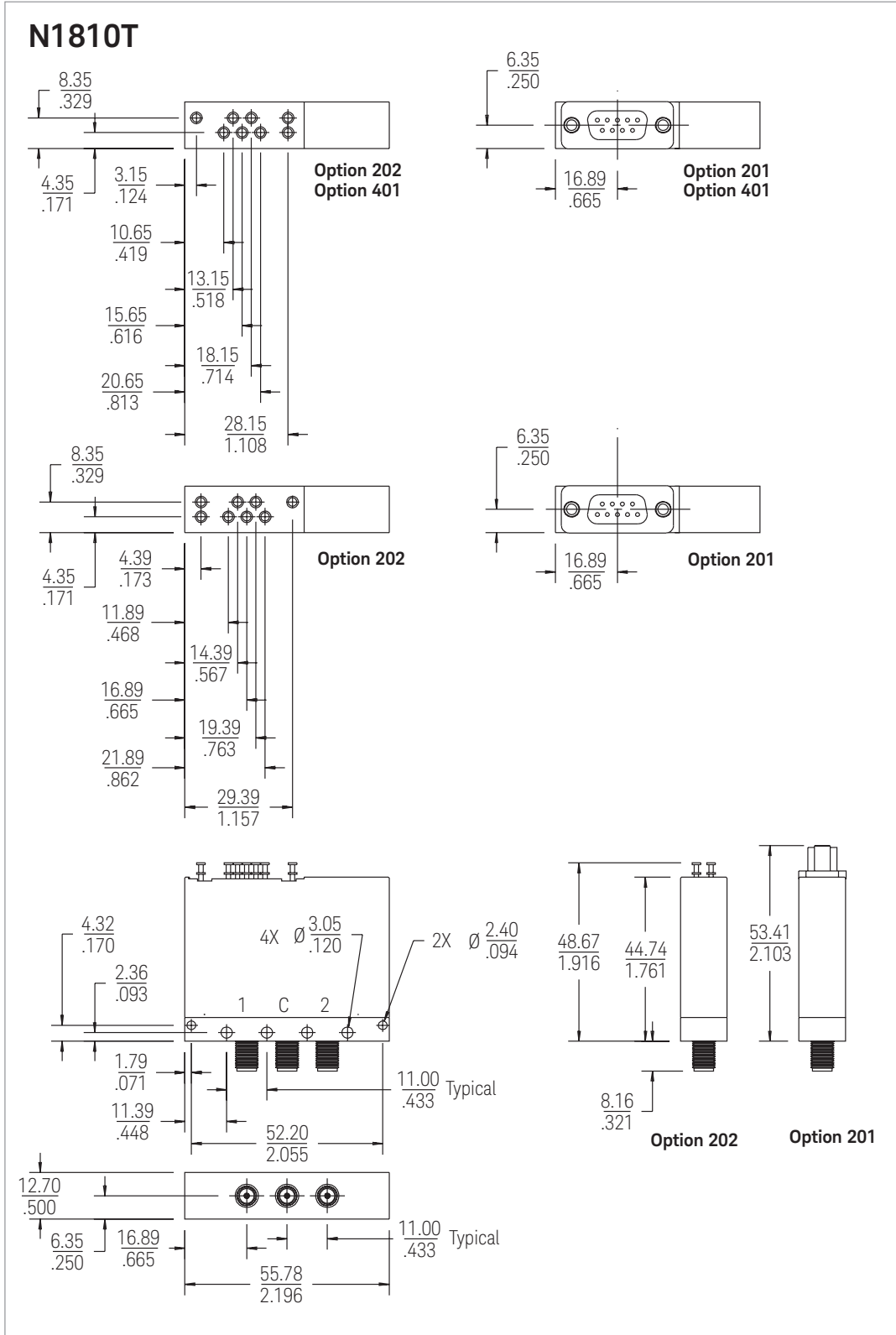

Figure 14.

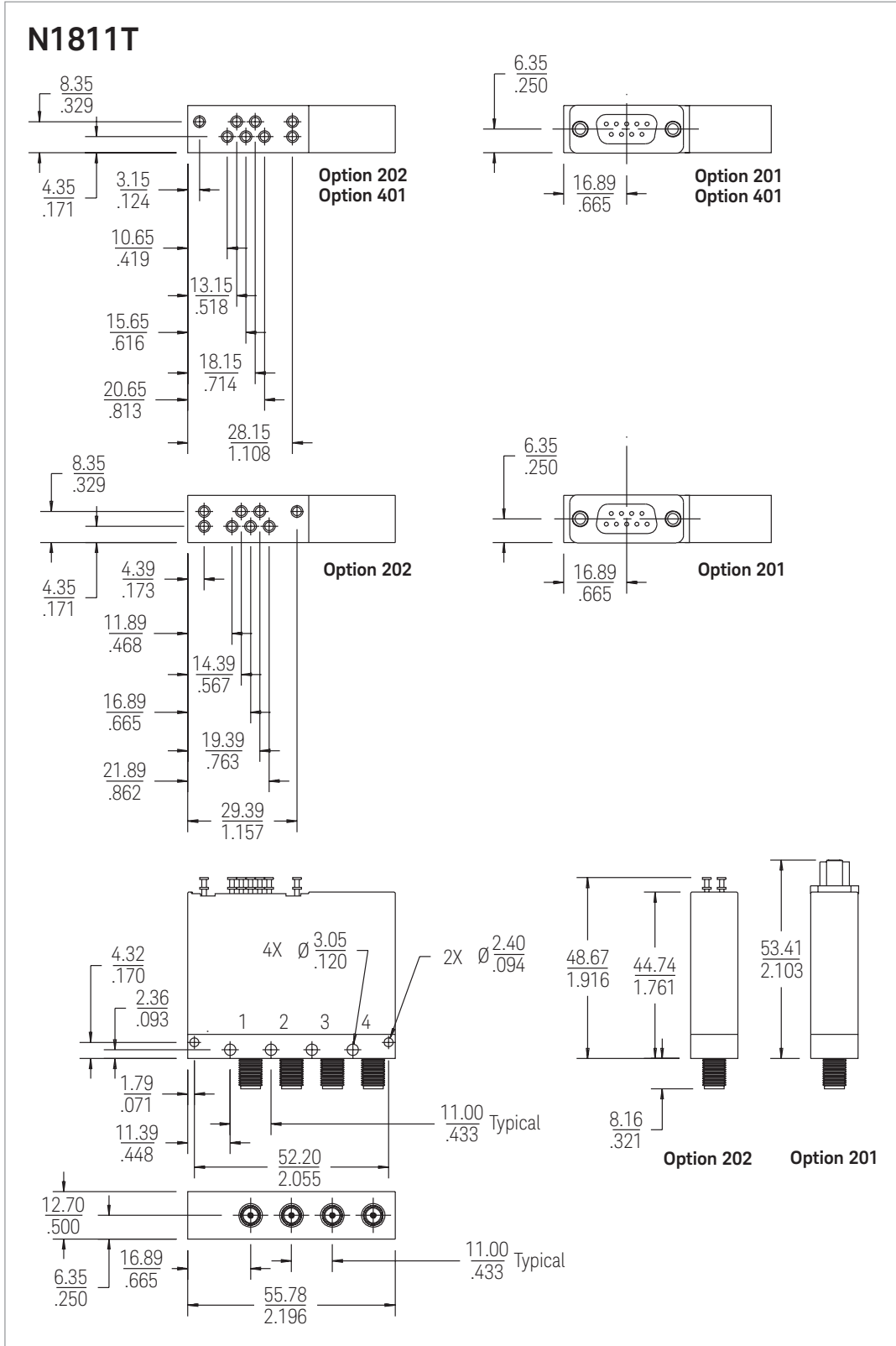

Figure 15.

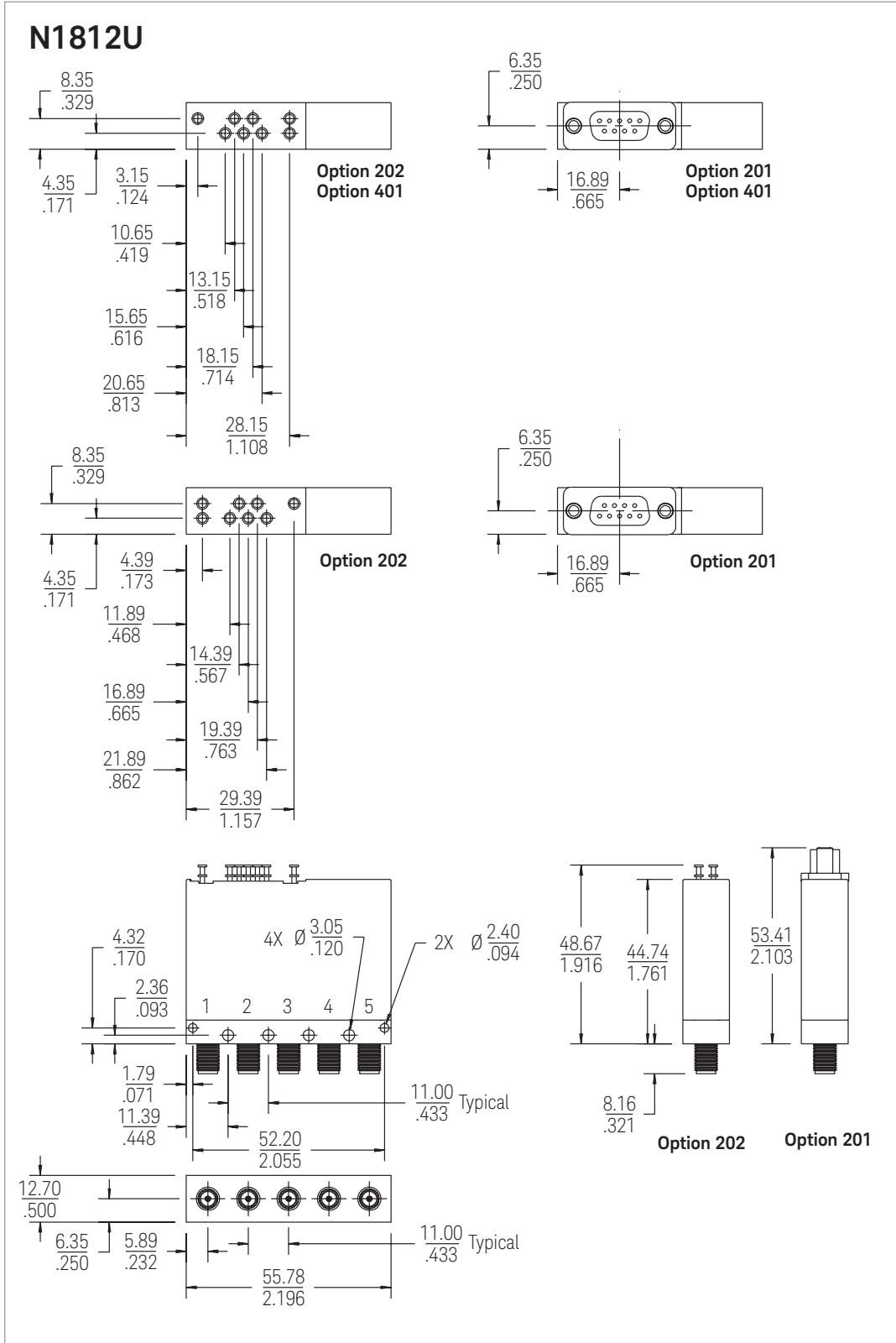

Figure 16.

## Ordering Information

Model	Description	16 pin DIP socket and connector with 24 inch ribbon cable	Solder terminals to replace ribbon cable	24 V DC without TTL Logic	TTL/5 V CMOS compatible	Mounting bracket (assembly required)
87104P	DC to 4 GHz, SP4T Terminated	Option 161	Option 100	Option 024	Option T24	N/A
87104Q	DC to 20 GHz, SP4T Terminated	Option 161	Option 100	Option 024	Option T24	N/A
87104R	DC to 26.5 GHz, SP4T Terminated	Option 161	Option 100	Option 024	Option T24	N/A
87106P	DC to 4 GHz, SP6T Terminated	Option 161	Option 100	Option 024	Option T24	N/A
87106Q	DC to 20 GHz, SP6T Terminated	Option 161	Option 100	Option 024	Option T24	N/A
87106R	DC to 26.5 GHz, SP6T Terminated	Option 161	Option 100	Option 024	Option T24	N/A
87222R <sup>1</sup>	DC to 26.5 GHz, Transfer	Option 161	Option 100	N/A	N/A	Option 201
87406Q	DC to 20 GHz, Matrix	Option 161	Option 100	Option 024	Option T24	N/A
87606Q	DC to 20 GHz, Matrix	Option 161	Option 100	N/A	N/A	

Model	Frequency range	Coil voltage	DC connector	Drive (optional)
N1810U: SPDT Un-terminated				
N1810T: SPDT Terminated	004: DC to 4 GHz	105: 5 VDC <sup>2</sup>	201: D-sub 9 pin (f)	401: TTL/5 V CMOS compatible
N1811T: 4-ports Bypass	020: DC to 20 GHz	115: 15 VDC	202: Solder lug	402: Position indicators
N1812U: 5-ports Bypass	026: DC to 26.5 GHz	124: 24 VDC		

- For 87222R, the connector type is 10 pin DIP socket.
- Option 105 includes Option 402.



myKeysight

[www.keysight.com/find/mykeysight](http://www.keysight.com/find/mykeysight)

A personalized view into the information most relevant to you.

[www.axiestandard.org](http://www.axiestandard.org)

[www.keysight.com/go/quality](http://www.keysight.com/go/quality)

Keysight Technologies, Inc.  
DEKRA Certified ISO 9001:2008  
Quality Management System



Keysight Channel Partners

[www.keysight.com/find/channelpartners](http://www.keysight.com/find/channelpartners)

Get the best of both worlds: Keysight’s measurement expertise and product breadth, combined with channel partner convenience.

[www.keysight.com/find/mta](http://www.keysight.com/find/mta)

[www.keysight.com/find/lowpim](http://www.keysight.com/find/lowpim)

For more information on Keysight Technologies’ products, applications or services, please contact your local Keysight office. The complete list is available at: [www.keysight.com/find/contactus](http://www.keysight.com/find/contactus)

**Americas**

Canada	(877) 894 4414
Brazil	55 11 3351 7010
Mexico	001 800 254 2440
United States	(800) 829 4444

**Asia Pacific**

Australia	1 800 629 485
China	800 810 0189
Hong Kong	800 938 693
India	0124 229 2010
Japan	0120 (421) 345
Korea	080 769 0800
Malaysia	1 800 888 848
Singapore	1 800 375 8100
Taiwan	0800 047 866
Other AP Countries	(65) 6375 8100

**Europe & Middle East**

Austria	0800 001122
Belgium	0800 58580
Finland	0800 523252
France	0805 980333
Germany	0800 6270999
Ireland	1800 832700
Israel	1 809 343051
Italy	800 599100
Luxembourg	+32 800 58580
Netherlands	0800 0233200
Russia	8800 5009286
Spain	800 000154
Sweden	0200 882255
Switzerland	0800 805353
	Opt. 1 (DE)
	Opt. 2 (FR)
	Opt. 3 (IT)
United Kingdom	0800 0260637

For other unlisted countries:  
[www.keysight.com/find/contactus](http://www.keysight.com/find/contactus)  
(BP-02-06-15)

